

## Servicing instructions

Note: Do not remove the magnets completely out of the filter. During servicing, individual magnets are to be lifted slowly to the service position only, commencing with the centre magnet first. The service height of the centre magnet is to be used as a guide when lifting all other magnets. Care should be taken if a magnet is entirely removed to avoid placing near another metallic or magnetic source.

It is necessary to keep the magnets and pockets dry at all times.

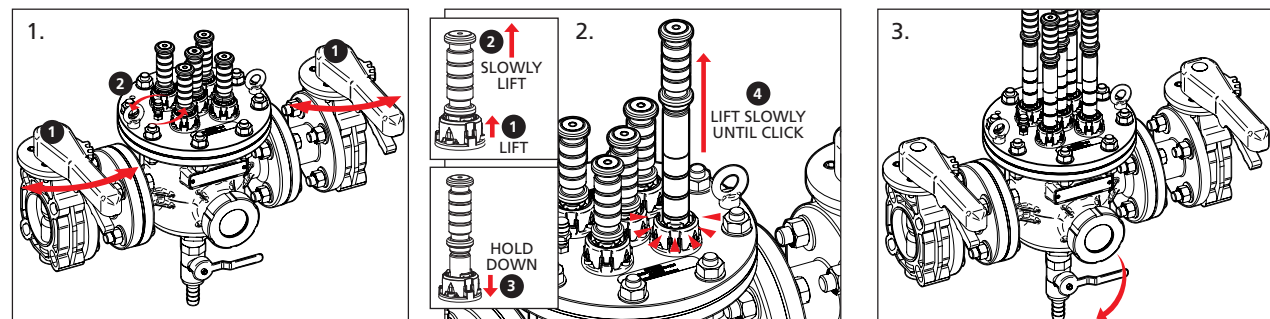

1. Check the MagnaClean sight glass for build-up of black iron oxide. Turn off the boiler and isolate the electrical supply prior to servicing. Turn off the isolation valves on either side of the product, then open the air vent located on top.

2. To position the magnets into service mode, lift and hold the grey locking ring, then carefully pull up the magnet. After the magnet is released, hold down the locking ring and continue to slowly lift the magnet assembly until it locks into the service position. Ensure that the magnets are not removed from the filter completely.

3. Connect a hose to the 1/4" drain valve or place a bucket underneath the unit. Open the drain valve or remove the drain plug.

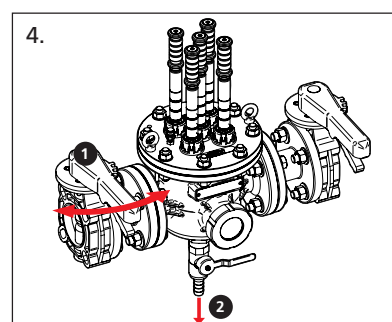

4. Partially open the inlet isolation valve, leaving the outlet isolation valve in the closed position and allow the deposits to drain through.

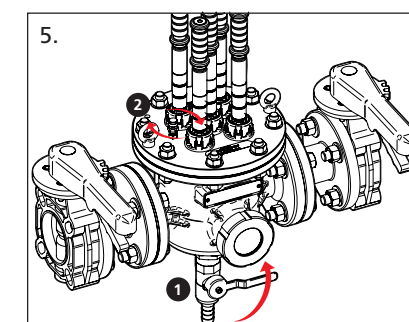

5. Close the inlet isolation valve once the water runs clear, then close the drain point by turning off the drain valve or replacing the drain plug. Close the air vent.

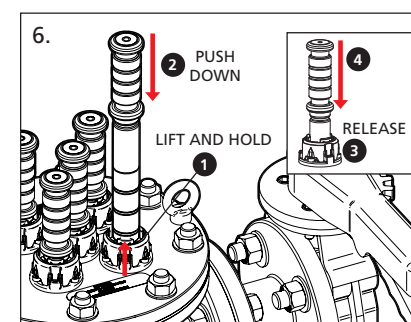

6. To replace the magnets to operational mode, lift and hold the grey locking ring up and slowly push the magnet assembly down. Release the locking ring and continue to slowly push down the magnet assembly until it locks into operational mode. Repeat the procedure for each magnet assembly.

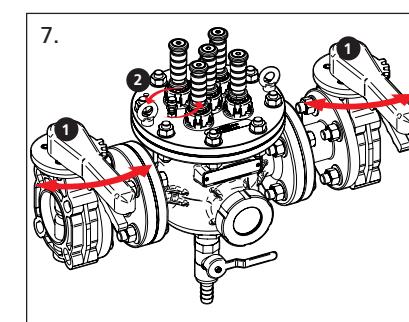

7. Re-open both isolation valves then refill the system as required. Bleed the air from the filter using the air vent. Ensure all magnets and pockets remain dry at all times. Remove any excess fluid from the top plate.

If seals are lost or damaged:

Please contact ADEY Customer Services Team on 01242 546717 or visit [adeyspares.co.uk](http://adeyspares.co.uk) to arrange replacements.

### CAUTION:

MagnaClean Commercial contains strong magnets. Keep away from all electrical devices, bank cards and other magnetic devices.

MagnaClean Commercial is a pressurised device. Always release pressure before servicing.

MagnaClean Commercial contains strong magnets. Caution should be taken at all times when handling if you have a pacemaker fitted.

Unit may be hot in operation. Handle with care.

# MagnaClean®



## Technical specifications

### MagnaClean

Maximum working pressure: 10 bar  
Maximum working temperature: 100°C

### Casing

Housing and lid material: 304L stainless steel  
Drain: 1/4" female BSP hole with 1/4" male BSPT plug  
Lid Seal: EPDM

### Flow Flanges

PN16  
Supplied with EPDM gaskets

### Magnets

Material: High power, 'rare earth' high intensity core  
Pocket sleeves: 304L Stainless steel

MagnaClean designed, manufactured and third party approved to EN 13445 : 2009

### Service warranty

The product is backed by a two year warranty.

### Inlet/outlet flanges

Size options: 2", 3", 4", 6", 8" Flanges: PN16 Standard

Filter size	Flange Thickness (mm)	Bolt size	Bolt quantity	Bolt hole PCD
2"	18	M16	4	125
3"	15	M16	8	160
4"	15	M16	8	180
6"	18	M20	8	240
8"	19	M20	12	295

### Sight glass

Weld material: DIN1.4404 stainless steel  
Collar nut: DIN1.4301/DIN1.4307 stainless steel  
Glass: Toughened soda lime to BS3463  
Product side seal: EPDM  
Outer seal: Non-asbestos fibre (KILINGERsil C-4400)

Product code	Filter size	Filter dry weight (kg)	Filter diameter (mm)	Inlet size (mm)	No. of magnetic rods	Filter volume (litres)
CP1-03-01123	2"	25.7	160	50	5	3.3
CP1-03-01124	3"	37.4	210	80	6	7.1
CP1-03-01125	4"	41.5	216	100	7	8.2
CP1-03-01126	6"	86.5	324	150	9	26.4
CP1-03-02147	8"	95.6	324	200	9	30.7

For more information on the installation and servicing of ADEY's MagnaClean Commercial, call 01242 546717 or visit [adey.com](http://adey.com)



## ADEY

PROFESSIONAL HEATING SOLUTIONS

Telephone: 01242 546717 Email: [info@adey.com](mailto:info@adey.com)

[adey.com](http://adey.com)



Produced from recycled material A carbon neutral company



© Adey Holdings (2008) Limited 2017. All rights reserved.

The Adey®, MagnaClean® and MagnaClean Commercial® logos and word marks are Registered Trademarks of Adey Holdings (2008) Limited used under license by Adey Innovation LLP. Patents apply (ADEY Industrial).

United Kingdom: GB2402894 Europe (Netherlands, Germany, Italy, France, Ireland, Belgium, Austria): EP1626809 USA: US3443983 and US7726492

# MagnaClean®

## Installation and servicing



## ADEY®



M05703 LF2-01-01147 V2

### Installation instructions

MagnaClean Commercial is an incredibly powerful range of magnetic filters designed to remove magnetite from light commercial heating systems through to heavy industrial applications.

The exceptional design characteristics and high production quality of MagnaClean Commercial make installation and ongoing maintenance extremely straightforward.

Correct installation and servicing is essential to ensure optimum operating performance and a longer operational life for the system.

### Flexible magnetic filtration options

As can be seen in the diagram below, MagnaClean Commercial provides a number of installation solutions in terms of unit size and location. The typical HVAC system illustrated identifies two of these options within the various circuits.

### Installation with Cascade (zoned) system

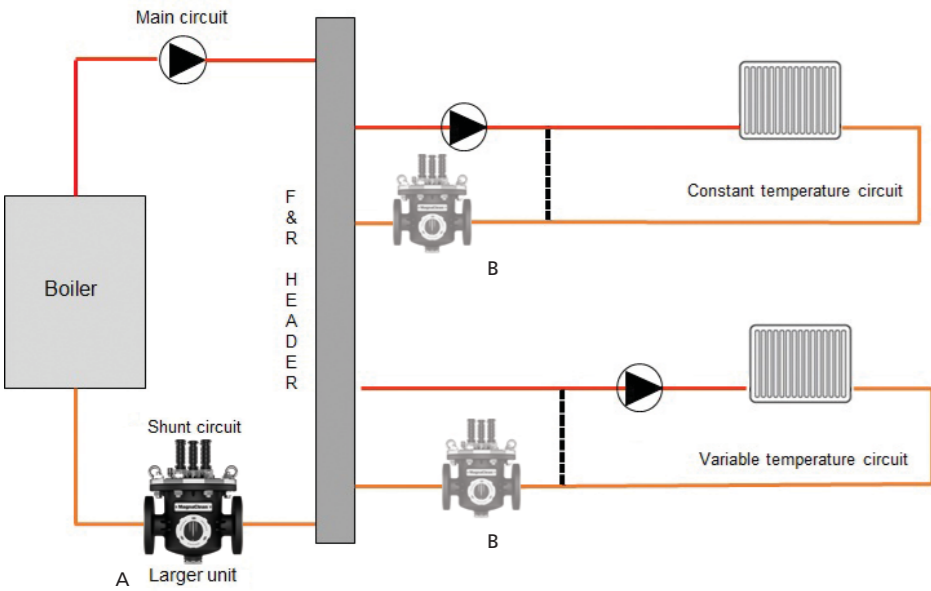

\* Position A is the recommended best practice installation option. Position B could be added in as an option to further protect the system.

### Installation with a Low loss header

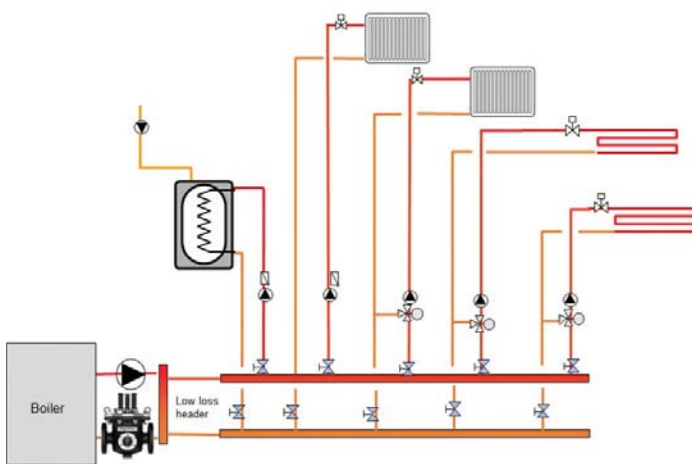

### Installation with a Plate to plate

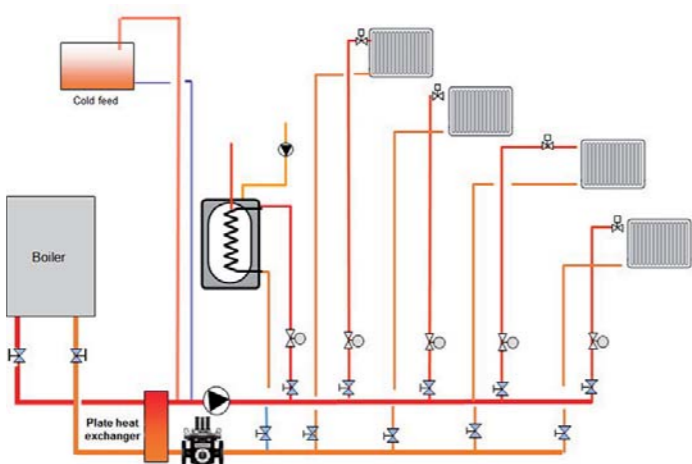

For chiller systems, it is recommended that a MagnaClean Commercial is installed on the return of the system before the chiller.

### Pressure drop graphs

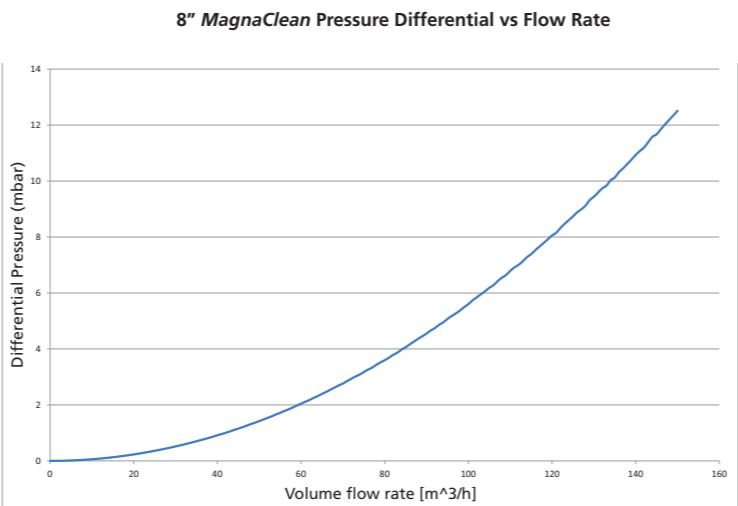
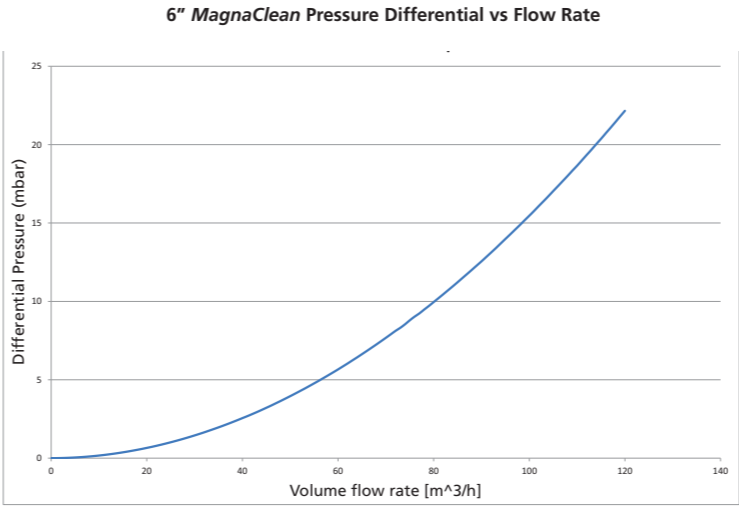
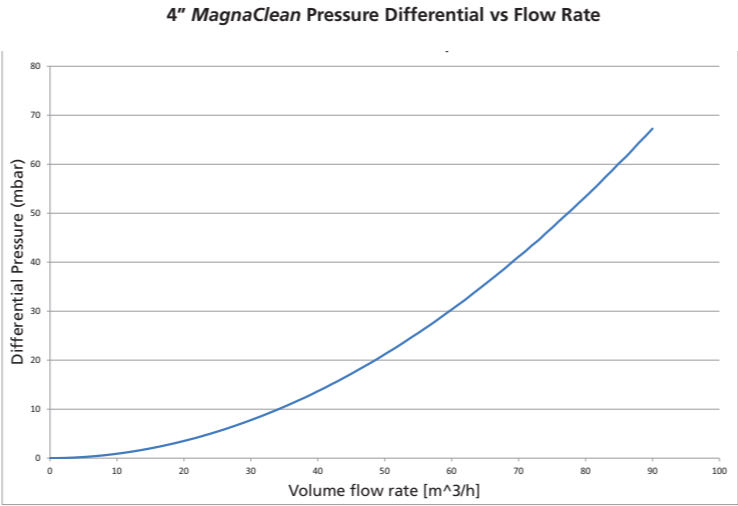
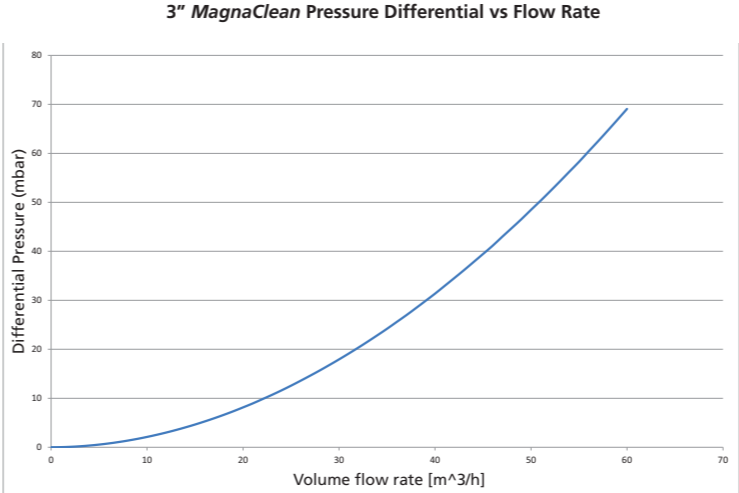
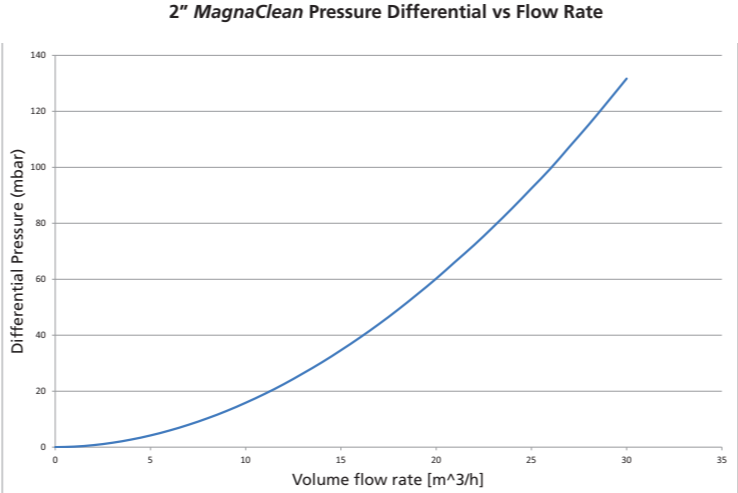

### Measurements table

ADEY product code	Description	Filter diameter (mm)	Inlet size (mm)	No. of magnetic rods	Measurement (mm)															
					A	B	ØC	ØD	ØE	F	G	H1	H2	J	ØK	L	M	N	P	
CP1-03-01123	2" filter	160	50	5	262	18	245	165	58	125	33	348	200	-9.5	160	18	4	98	239	
CP1-03-01124	3" filter	210	80	6	330	15	295	200	87	160	45	388	225	2.5	210	18	8	113	265	
CP1-03-01125	4" filter	216	100	7	360	15	299	220	110	180	57	403	248	15.5	216	18	8	139	253	
CP1-03-01126	6" filter	324	150	9	470	18	430	285	166	240	55	503	270	2	324	22	8	157	335	
CP1-03-02147	8" filter	324	200	9	538	19	430	340	222	295	88	505	340	35	324	22	12	192	302	

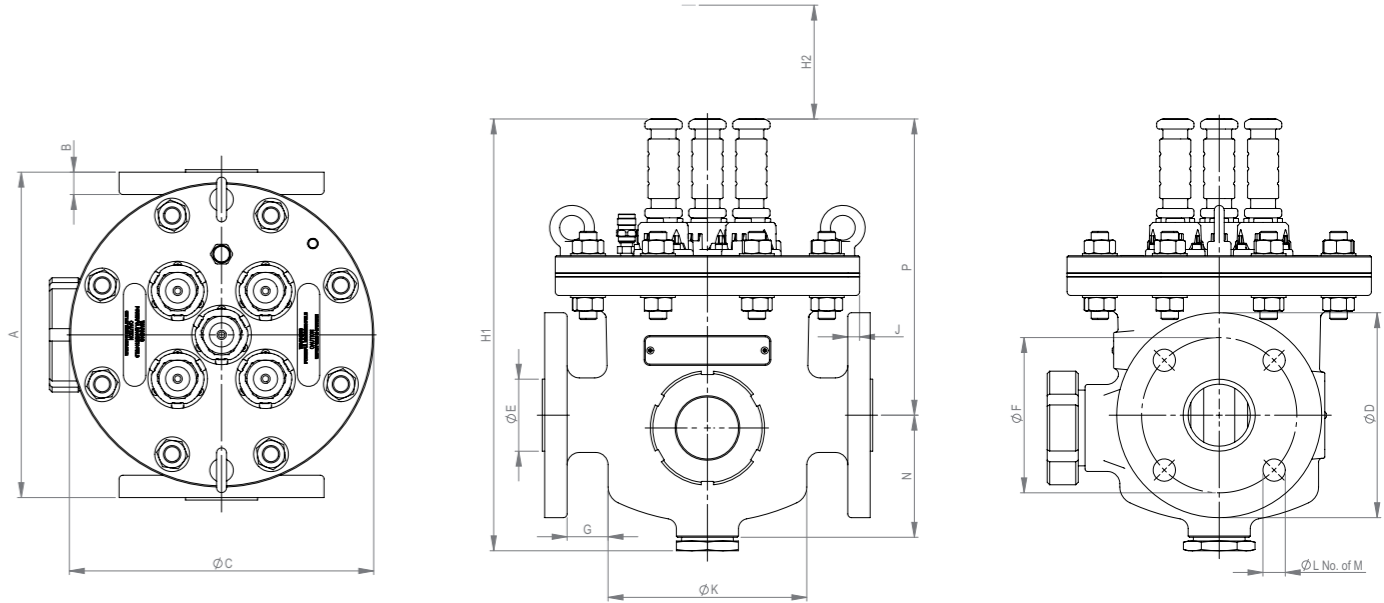

### Step by step guide to installation

NOTE: Do not remove the magnets completely out of the filter. Individual magnets, during servicing, are to be lifted slowly to the service position only (see servicing instructions for more information). If a magnet is entirely removed, care should be taken at all times to ensure the magnets are not placed near another metallic/magnetic source.

It is necessary to keep the magnets and pockets dry at all times.

NOTE: We recommend that MagnaClean Commercial is fitted on the primary circuit on the return to the boiler.

IMPORTANT: The filter must be installed in an upright position.

Follow the illustrations and measurements for easy installation of MagnaClean Commercial.

### There are four key steps to successful installation:

- Step 1**  
Use the measurements table to identify the correct length of pipe work to be cut-out (refer to measurement 'A'). Allow extra length for isolation valves as required.  
It is recommended for the filter to be fitted on the primary circuit on the return to the boiler. Give consideration to the area above MagnaClean Commercial to access the magnets during servicing. Refer to dimension 'H2' on the measurement table above.
- Step 2**  
Install the isolation valves and connect the two PN16 flanges to the isolation valves using appropriate fittings and suitable gaskets.
- Step 3**  
Install the MagnClean Commercial ensuring that all fittings are aligned correctly and secure. Remove the drain plug from the base underside of the unit. Install a fixed pipe and drain valve to the 1/4" BSP drain point at the base of the unit. Alternatively place a bucket underneath the unit and remove the drain plug during servicing.
- Step 4**  
Check the MagnaClean Commercial product has been installed correctly. Proceed to run the system for a period of time, ensuring the isolation valves are fully open and check there are no leaks present.